

Thermo-Regulator

user manual

The HomeBiogas Thermo-Regulator ensures that the system remains in optimum conditions, in the most energy-efficient manner. Temperature is one of the most critical parameters for biogas production - the Thermo-Regulator stabilizes the system's temperature, creating a more resilient, productive, and durable HomeBiogas system.

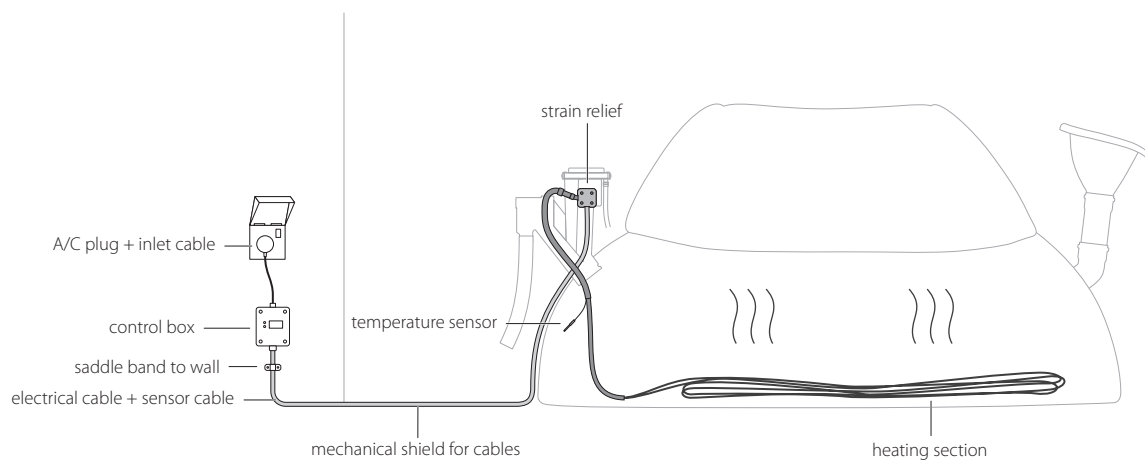

The Thermo-Regulator consists of a submersible heater that is connected to a controller with a temperature sensor. The controller is installed inside an outdoor electrical box with indicator lights showing the current operating state of the heater.

Safety Instructions

1. This section contains important safety and operating instructions. Read and keep this user manual for future reference.
2. High Voltage! Do not touch wires while connected to the outlet – heating section included.
3. Do not use the Thermo-Regulator for any purpose other than its intended use.
4. Do not use the appliance in temperatures below $-5^{\circ}\text{C}/23^{\circ}\text{F}$. Do not store the appliance in temperatures below $-20^{\circ}\text{C}/-4^{\circ}\text{F}$.
5. Ensure the input voltage of your Thermo-Regulator model matches your local power supply.
6. Do not use the Thermo-Regulator if it has a damaged cord or plug, or if it is malfunctioning or damaged in any manner.
7. Do not pull on the cable to remove the plug from the socket - pull on the plug carefully to disconnect it.
8. Do not disassemble the product. Attempting to service the Thermo-Regulator by yourself may result in a risk of electrical shock or fire.
9. Unplug the Thermo-Regulator from the electrical outlet when not in use or before any type of maintenance or cleaning.
10. A G.F.C.I (Ground fault circuit interrupter) & Residual Current Device (RCD) is mandatory.
11. Do not attempt to repair the Thermo-Regulator.
12. If you are unsure about your electrical infrastructure, consult a qualified electrician.
13. Ensure the conduit pipe is protected all along its routing.

Thermo-Regulator installation

Parts Provided

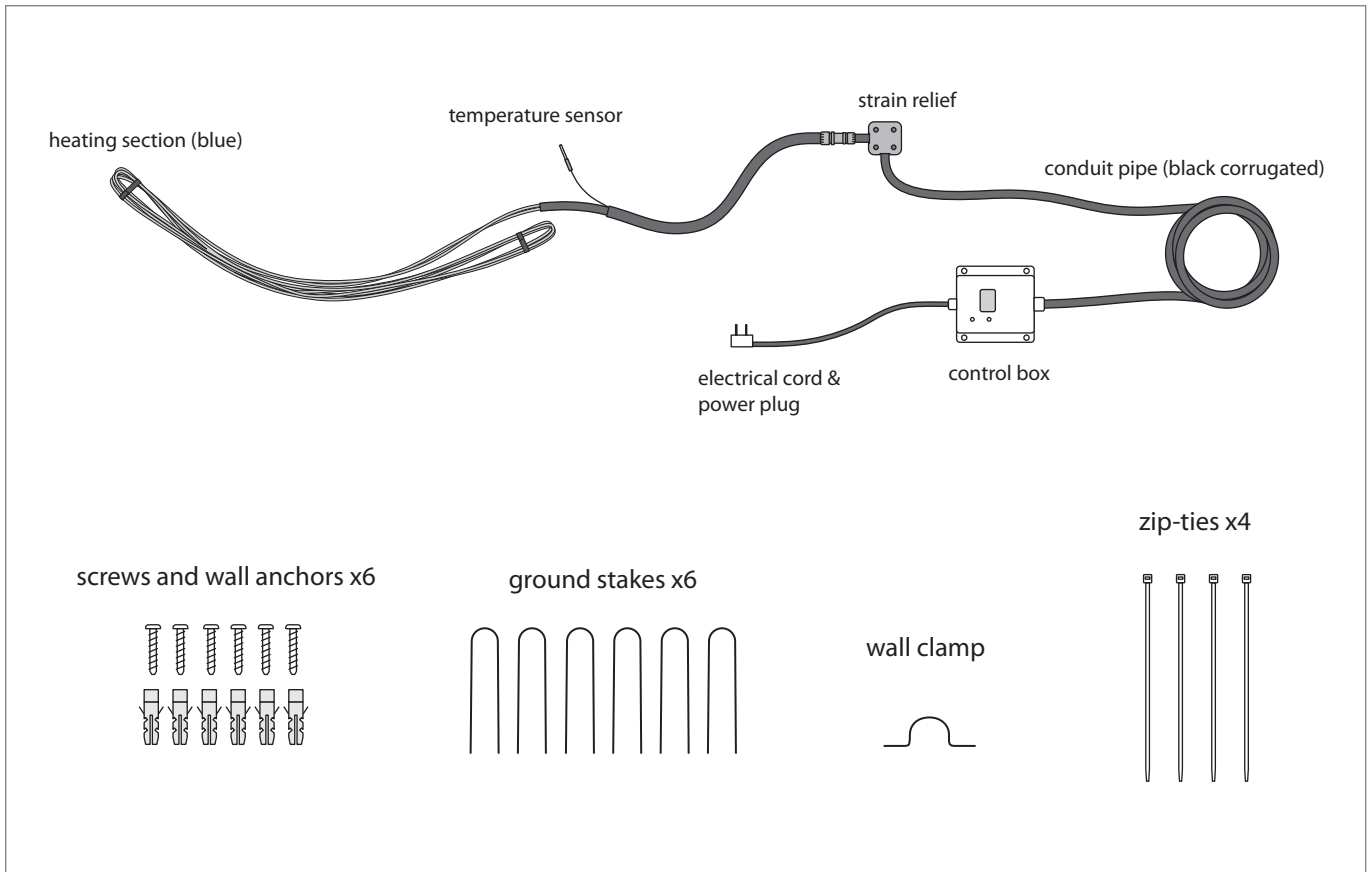

Tools Required

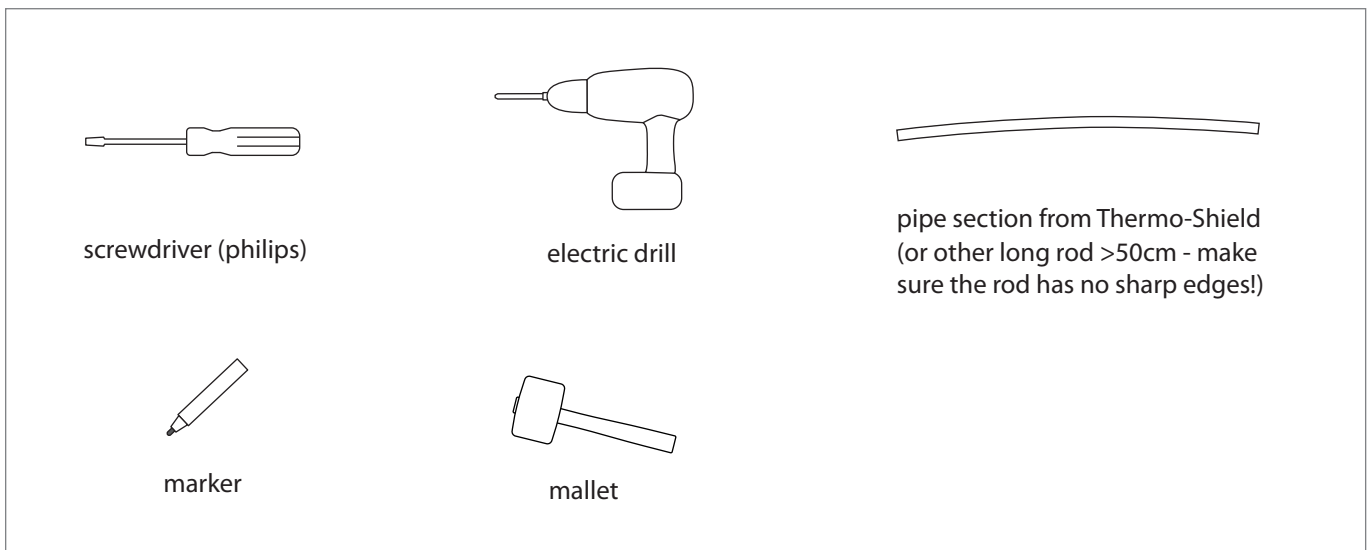

1. Remove fertilizer cap from fertilizer outlet

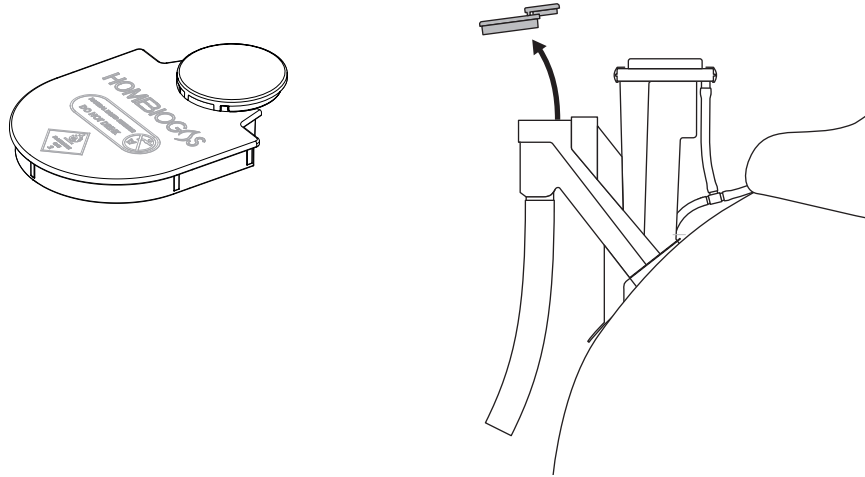

Remove the cap from the fertilizer outlet section of the combined outlet. The cap is not needed while the heater is installed inside the system.

2. Attach strain relief to the mounting points on the Combined Overflow

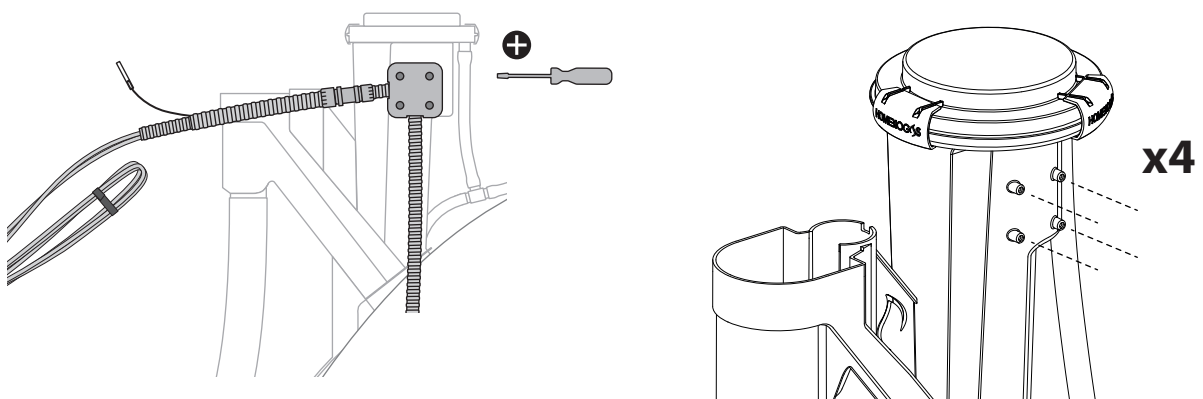

Using a Philips screwdriver, attach the strain relief (square box along conduit) to the 4 attachment points on the combined outlet. **The screws come pre-installed in their sockets on the strain relief. (To avoid damaging the system, do not use a powered screwdriver!)**

3. Insert heating section of the Thermo-Regulator into the system

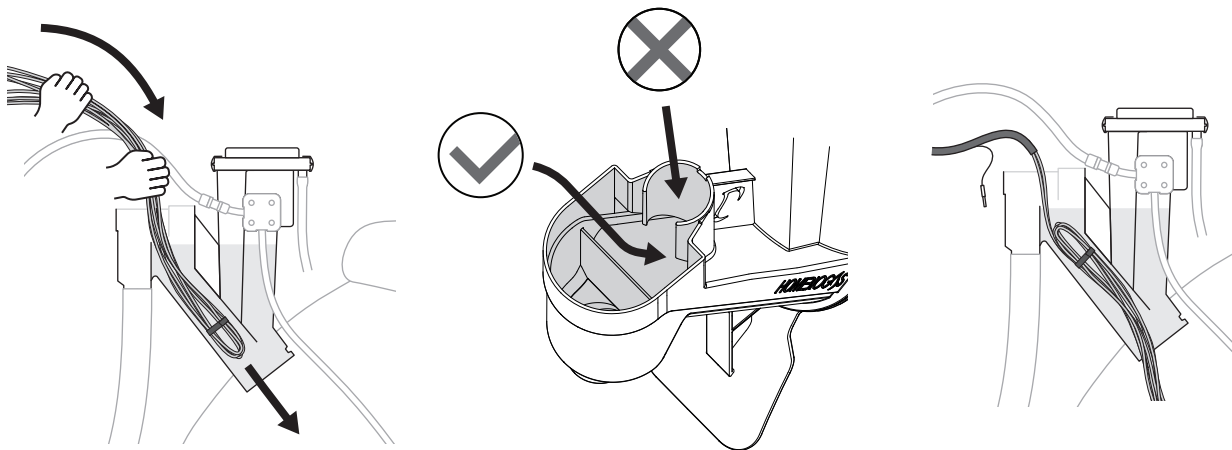

Insert the entire heating section (blue cables) into the digester through the combined outlet. Start by inserting the end into the space to the front of the circular port (not the circular section). Carefully insert the heater as far as it will go by hand. **Do not remove the attachment holding the heating element loops together.**

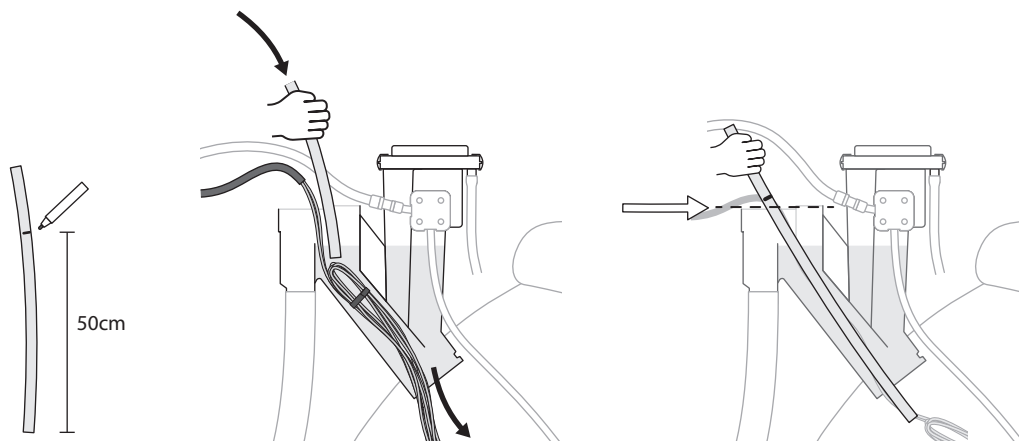

Use a rod to push the heater all the way into the system. Mark 50cm along a suitable pipe/rod **with no sharp edges**. Carefully use the pipe to push on the ending section of the heating element's loops. Push the heater in until the 50cm marking on pipe reaches the rim of the fertilizer outlet. **Do not push the pipe past the 50cm marking.**

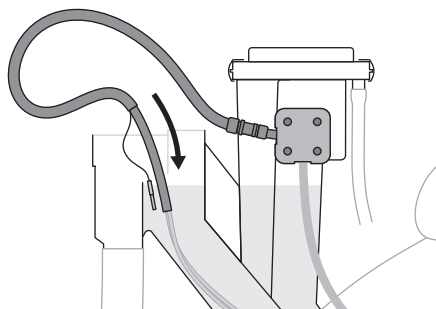

Continue inserting black corrugated conduit - carefully insert the temperature sensor to prevent any damage, followed by the remaining conduit.

4. Connecting the plug and cable management

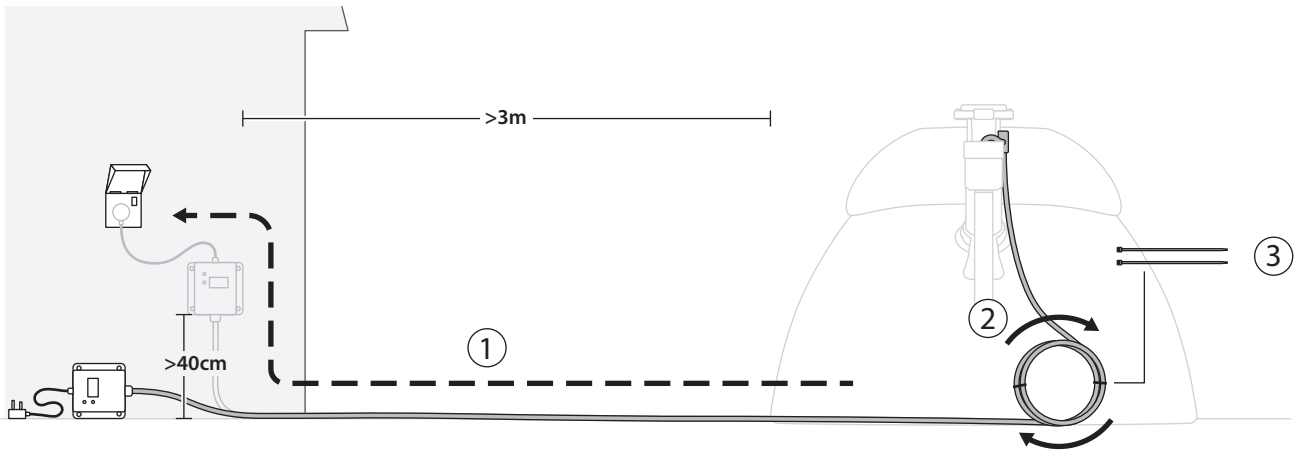

Route the conduit along a suitable path to the intended power outlet - make sure you can plug into the outlet without straining the cable. The control box should be located **at least 40cm from the ground, and 3m from the system**. Coil the excess conduit neatly at the system and fasten the coils with the included zip ties. **Do not plug into outlet yet.**

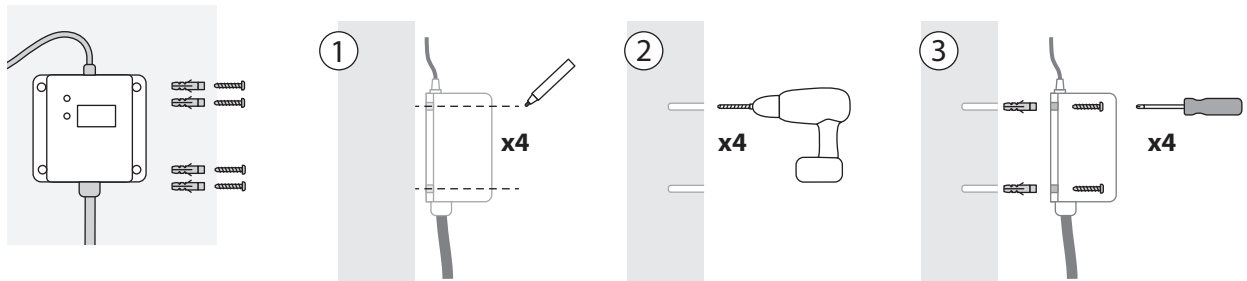

Place the control box at its final position near the weatherproof power outlet, and mark the positions where the 4 screws should go into the wall. Drill the 4 holes, then insert the wall anchors, and screw the control box in place.

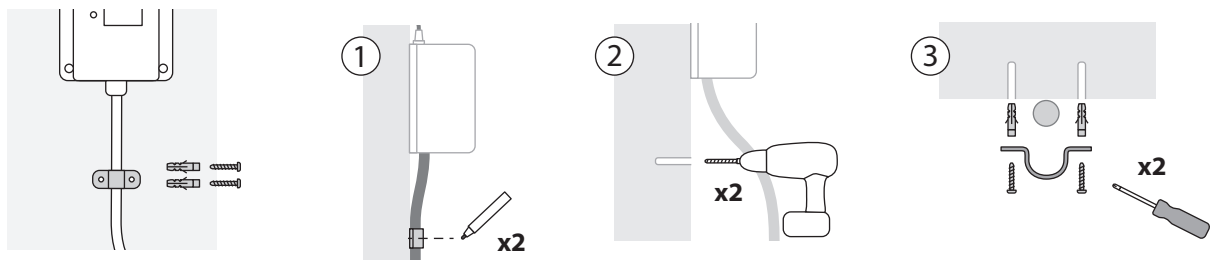

Use the U-clamp to fasten the conduit to the wall below the control box - mark the desired position of the clamp, drill 2 holes for the screws, and insert wall anchors, then screw the clamp in place.

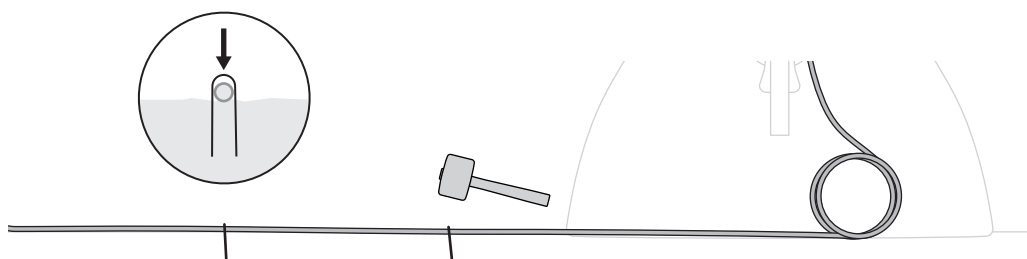

Use U-stakes provided to fix the conduit into the ground at intervals along its route. Use a mallet to drive stakes into the ground over the conduit.

Thermo-Regulator operation

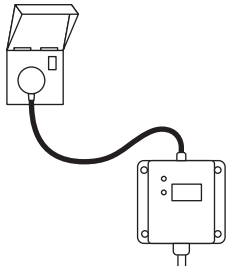

Plug the Thermo-Regulator into the power socket and turn the outlet on (make sure outdoors power sockets are weatherproof).

Once installed, the Thermo-Regulator can be left on permanently - a temperature sensor in the system will only turn the heater on when necessary.

Controller Display & Indicator LED guide

<p>On <input type="radio"/></p> <p>Heating <input type="radio"/></p>	<p>All lights off</p> <p>System not turned on</p>
<p>On <input checked="" type="radio"/></p> <p>Heating <input checked="" type="radio"/></p>	<p>Bottom LED blinks twice, speaker beeps twice</p> <p>System booting up</p>
<p>On <input checked="" type="radio"/></p> <p>Heating <input type="radio"/></p>	<p>Top LED on</p> <p>System running, not currently heating. Current temperature displayed.</p>
<p>On <input checked="" type="radio"/></p> <p>Heating <input checked="" type="radio"/></p>	<p>Both LEDs on</p> <p>System running, heating. Current temperature displayed.</p>
<p>On <input checked="" type="radio"/></p> <p>Heating <input type="radio"/></p>	<p>Display reads 'E1'</p> <p>Temperature sensor faulty, heating is off</p>
<p>On <input checked="" type="radio"/></p> <p>Heating <input type="radio"/></p>	<p>Display reads 'H1'</p> <p>High temperature alarm warning</p>

specifications

	EU / Israel / Oceania	North America
product name	Booster Kit/Thermo-Regulator	Booster Kit/Thermo-Regulator
model no.	22470002 (EU), 22470003 (IL), 22470004 (AUS/NZ)	22470005
dimensions	Box: 40 x 30 x 15 cm Control Box: 12.9 x 11.5 x 7.0 cm	Box: 15.7 x 11.8 x 5.9 in Control Box: 5.1 x 4.5 x 2.8 in
gross weight	4.1 kg	9 lbs
net weight	3.5 kg	7.7 lbs
cable length	Conduit: 7m Heater: 20m Power Cord: 45cm	Conduit: 23 ft Heater: 65.6 ft Power Cord: 17.5 in
operating temperature	-5°C - 50°C	23°F - 122°F
storing temperature	-20°C - 60°C	-4°F - 140°F
voltage	220V	110V
power	Max 2200W	Max 1900W
IP rating	Control Box: IP55 Temperature Sensor: IP68	Control Box: IP55 Temperature Sensor: IP68
place of origin	China	China

CE Certifications:

EMC:

EN 55014-1:17+A11:20;

EN 55014-2:15;

EN 61000-3-2:14;

EN 61000-3-3:13+A1:19;

AS CISPR 14.1:18;

EN IEC 61000-3-2:19;

EN 55014-2:15, Category IV;

AS/NZS CISPR 14-2:15, Category IV

Safety:

IEC/EN 60335-1

AS/NZS 60335.1:2020 +A1:2021



